

7	8	9	10
MAPX	MODIFICATION		DATE

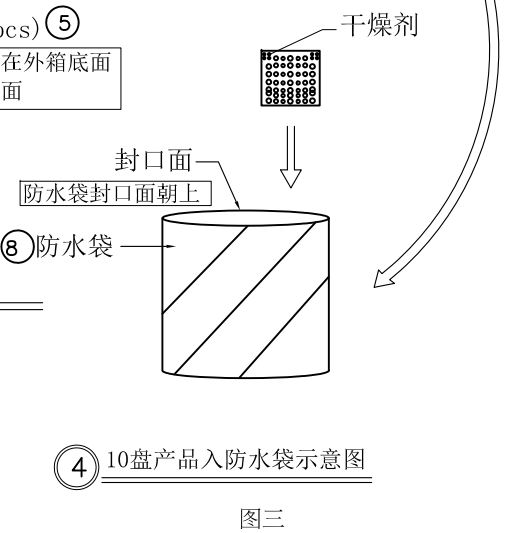
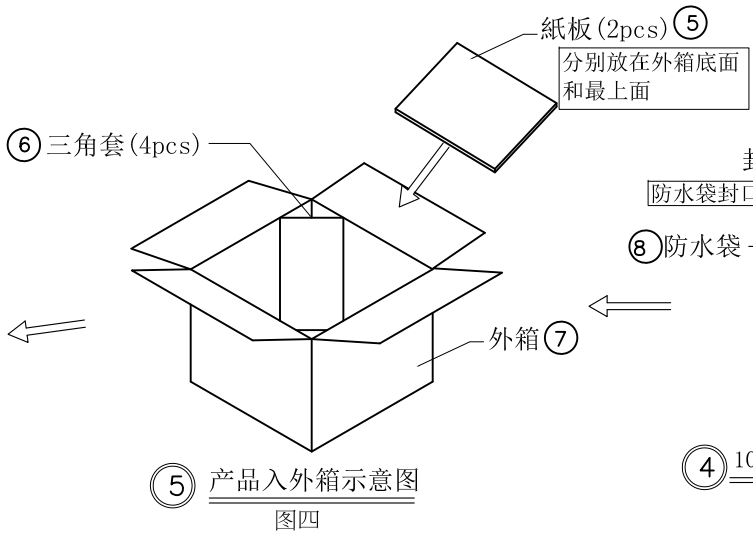
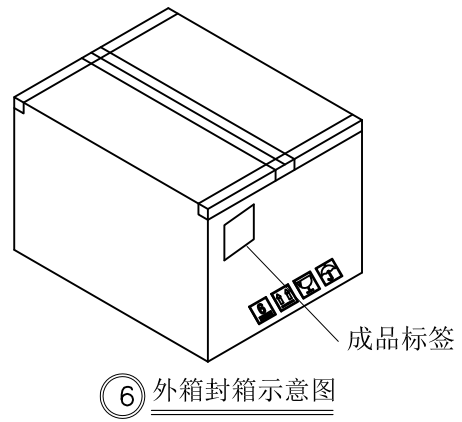
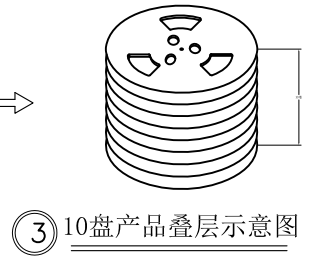
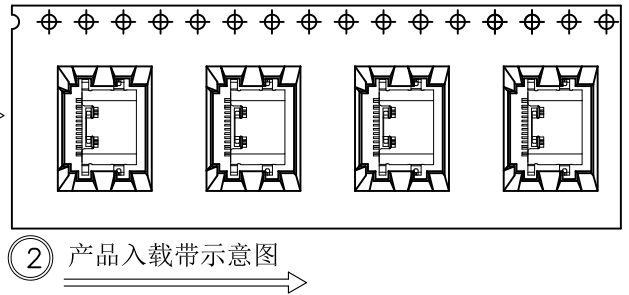
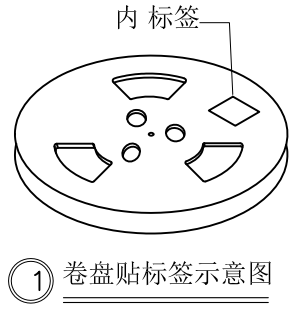

包装说明:

1. 将检验好的成品;SMT朝下放入载带底部;每卷装1400PCS产品,14000PCS/箱;具体如图一所示
2. 将包装好的产品;每盘必需贴上内标签;具体如图二所示
3. 将贴好内标签的产品每10盘叠一层装入防水袋中并加一包干燥剂;装好后将防水袋封好;具体如图三图四所示
4. 先将1pcs平卡放入纸箱底部;然后将装好产品的防水袋装入纸箱中;防水袋热熔封口,封口面需朝上;并将4PCS三角套分别装入4个角;如图五所示
5. 装好后将1pcs平卡放入纸箱最上面并封好纸箱及贴好相关标签;具体如图六所示;(产品包装的标签,如客户有要求,请按客户要求包装出货)
6. 载带前面留30PCS空格,后面留20PCS空格
7. COVER与CARRY剥离力:50-125g,速度:300mm/分钟左右,剥离角度:165°-180°

<p>产品图 PRODUCT CHART DWG</p> <p>公差一览表 TOLERANCE UNLESS OTHERWISE</p> <table border="1"> <tr> <td>X.</td> <td>±0.35</td> <td>X.</td> <td>±5.</td> </tr> <tr> <td>.X</td> <td>±0.30</td> <td>.X</td> <td>±2.</td> </tr> <tr> <td>.XX</td> <td>±0.20</td> <td>.XX</td> <td>±1.</td> </tr> <tr> <td>.XXX</td> <td>±0.10</td> <td>.XXX</td> <td>±0.5.</td> </tr> </table>				X.	±0.35	X.	±5.	.X	±0.30	.X	±2.	.XX	±0.20	.XX	±1.	.XXX	±0.10	.XXX	±0.5.	<p>深圳市精拓金电子有限公司</p>							
X.	±0.35	X.	±5.																								
.X	±0.30	.X	±2.																								
.XX	±0.20	.XX	±1.																								
.XXX	±0.10	.XXX	±0.5.																								
单位 UNITS	MM	制图 DRAWING	Gavin	制图料号 PRODUCT PART NO.																							
比例 SCALE	1:1	审核 CHKD	郭治富	产品名称 PRODUCT NO.	USB 3.1 C TYPE母座卷装图																						
日期 DATE	2016-11-09	核准 APPD	黄国荣	角法 VIEW	版本 VER	AO																					